

VAF

INSTRUMENTS



ViscoSense[®] 3/3D

Viscosity Measurement & Control Systems
Density Measurement enabling Mass Flow

782

Product Bulletin

WWW.VAF.NL

TO BE
REALLY
SURE

Introduction

With decades of experience VAF Instruments is the worldwide market leader for in-line viscosity measurement and control systems. ViscoSense®3 and ViscoSense®3D are the latest innovative developments in a long history of outstanding viscosity sensors for fuel oil applications. In this most demanding environment of diesel engines on board ships and in land based power plants, VAF Instruments has proven itself with high quality products and a comprehensive and professional customer support.

Necessity of viscosity control

Most of the operating costs of a ship are fuel related. Therefore it is very important to use fuel in the most efficient way. A large variation in the quality and composition of fuel oil makes the behaviour of the fuel oil at higher temperatures difficult to predict. An optimal viscosity is needed for the best possible atomization of HFO in the engine, so the fuel will be burnt completely without remaining deposits. The measurement and control of the viscosity ensures an improved combustion efficiency, preventing engine damage and reducing cost of maintenance.

Mass flow measurement

In general fuel is bought in metric tonnes. Therefore, to be consistent, fuel consumption is more and more monitored in kilograms. Smart usage of (existing) VAF Instruments PD Flowmeters in the fuel system in combination with ViscoSense®3D enables mass flow measurement. In bunkering applications measurement of viscosity and density by ViscoSense®3D enables the detection of possible cappuccino effect.

Accuracy and reliability

ViscoSense®3(D) is a highly accurate viscosity sensor with a superior measuring principle. This patented measuring principle is based on a torsional vibration of a pendulum in liquid. The measured damping of this piezo-driven vibration is directly related to the viscosity, whilst frequency is related to the density. A built-in temperature sensor is used to measure the temperature at the same location where viscosity and density are measured. Due to the operating principle based on a torsional vibration, the measurement is insensitive to unwanted external influences. Flow velocity, flow direction and pulsations have no effect on the sensor operation. The robust sensor is designed to operate under the most difficult conditions in which faultless and stable viscosity and density measurements are required.

Cost-effective operation

The ViscoSense®3(D) sensor is developed to measure viscosity and density without interruptions and with low operating costs. Since the sensor does not actually move, it is not subject to wear and therefore it ensures a long lifetime and a maintenance free operation. The surface of the pendulum (which has undergone special surface treatment to improve its non-stick performances) in combination with a smooth edged design makes the sensor highly insensitive to fouling and easy to clean. The sensor is calibrated for life and the accuracy will be kept without the necessity of re-calibration. Due to its compact design, the sensor is suitable for easy installation in any new or retrofit system.

ViscoSense® is a registered trade mark of VAF Instruments.

Principle of operation

The operating principle of the sensor is that of a torsion pendulum. The sensor consists of a stainless steel sensor head, attached to the base plate by means of a tubular torsion spring. In the head, one pair of piezo elements (driver piezos) actuates the pendulum at its torsional resonance frequency, while another pair of piezos detects the actual movement of the head. In a low viscosity medium, like air, the resonance frequency is in the range of 1600 Hz. In a high viscosity medium the movement of the head is damped by the liquid. Consequently, the resonance frequency slightly shifts towards lower frequencies, whilst the width of the resonance peak increases, which is a measure for the viscosity.

A ViscoSense®3D sensor head is equipped with a cross vane through which a small amount of fluid is increasing the mass moment of inertia. The frequency of the pendulum, which is dependent on the mass moment of inertia, is now directly related to the density of the fluid.

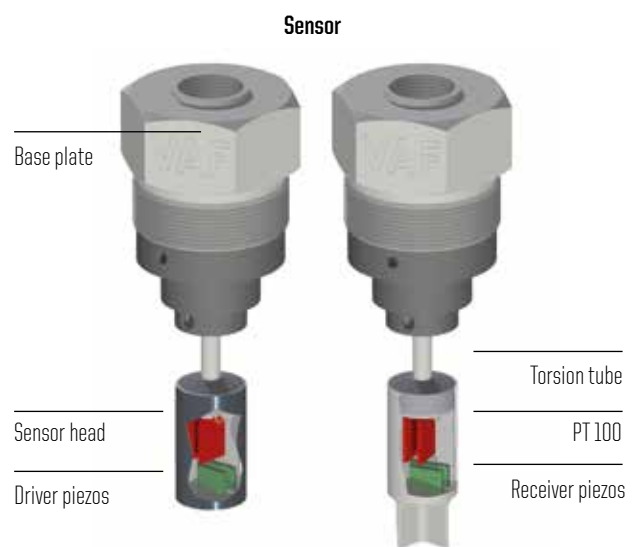
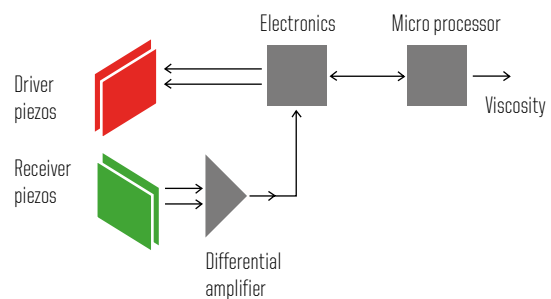

Typical system arrangement

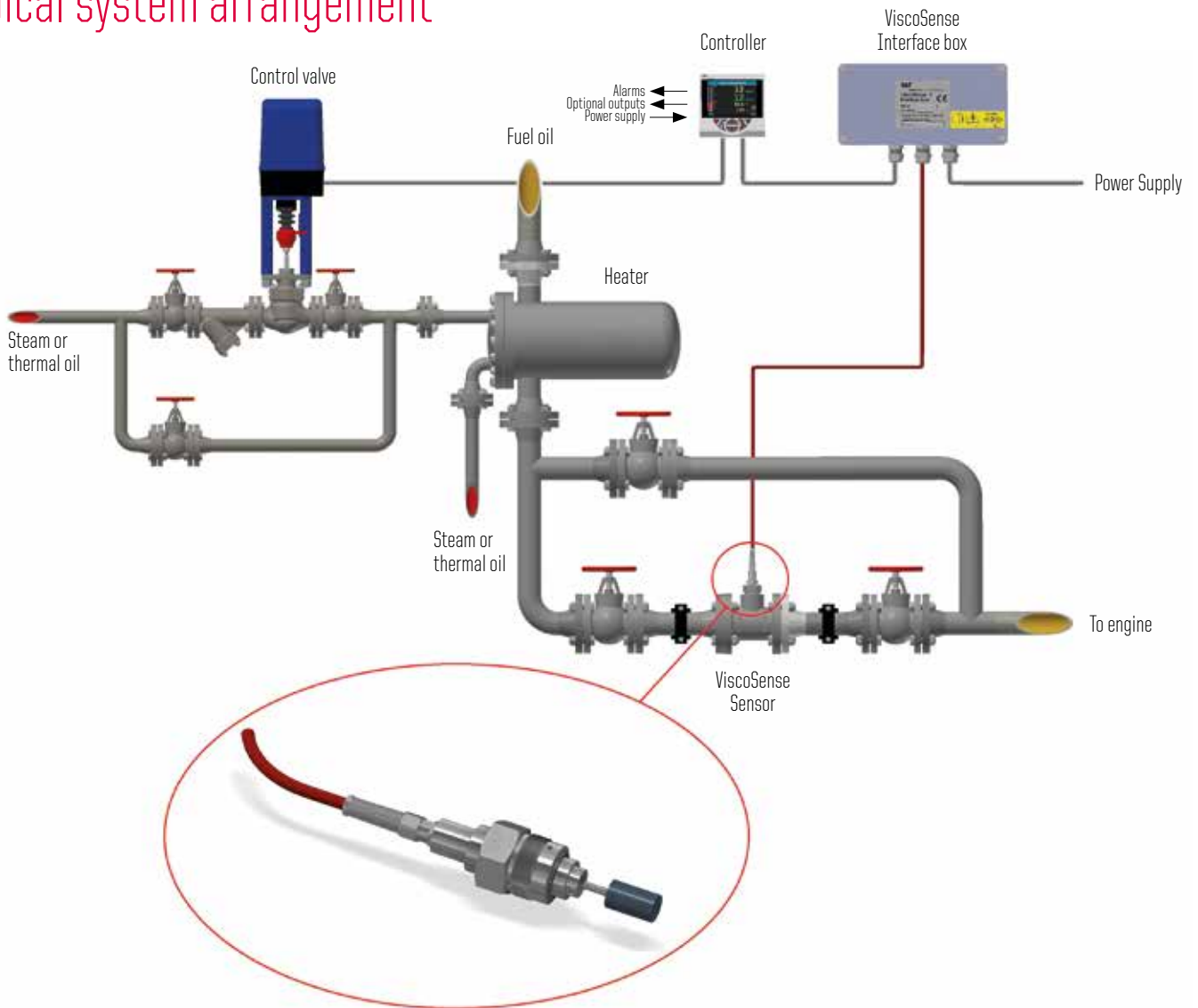

Cost-effective solution

To enable mass flow measurement, only a small upgrade of your current system is required.



One ViscoSense®3D can be combined with one or multiple Flowmeters in the same fuel system, independent of configuration. Fuel consumption measurement by VAF Instruments' Positive Displacement Flowmeters in combination with density measurement by the ViscoSense®3D is a cost-effective solution that enables mass flow measurements with highest accuracy, reliability and repeatability.

Features and benefits

As a result of the torsional vibration technique, the flow velocity has no effect on the measurement. External vibrations have no influence on the ViscoSense®3(D). In practice the smooth edged design of the sensor makes the system highly insensitive to fouling and easy to clean. In addition the closed-loop controlled torsional vibration principle is independent of ageing of piezo material, ensuring a long term stable and accurate measurement.

Features

Benefits

Stable and accurate in-line measurement

Optimal burning efficiency and fuel consumption

Torsional vibration measuring principle

Engine damage prevention and reduced maintenance

Reliable under all circumstances

No moving parts

Not influenced by vibrations, flow velocity or dirt particles

No preventive maintenance required

Minimal load on components

Low operating costs

No ageing and wear effects

Stainless steel 316L pendulum

No wear due to corrosion

Durable

Smooth edged pendulum

Insensitive to adherence

Compact light-weight construction

Easy to install

Calibrated for life

Long and trouble-free operation

Type approval from all major classification authorities

To be implemented directly on any ship without additional costs



Applications

ViscoSense®3/3D systems are used in a variety of systems such as:

Marine applications

In-line viscosity control is required when (ships) diesel engines or - burners are operated on (heavy) fuel oil, since there is a large variety in quality of this fuel. A correct viscosity ensures an optimal burning efficiency of the fuel, and therefore reduces operating and maintenance costs. Mass flow measurement enables to monitor fuel consumption in kilograms instead of litres. This can be realised by combining ViscoSense®3D density measurement with a positive displacement Flowmeter, which assures best possible accuracy.

Industrial applications

The ViscoSense®3 sensor is also suitable for the in-line measurement of viscosity of many liquids in industrial applications. In addition, the ViscoSense®3D sensor is suitable for density measurement. Because individual applications need special attention please contact VAF Instruments for a tailor made solution.

Options and accessories

FCM2 Flowcomputer

An FCM2 Flowcomputer can be used for visualization of mass flow measurements, when one or two PT2 Flowmeters are connected in combination with a ViscoSense®3D density sensor.



FCM2 Flowcomputer

Electric heater control cabinet

The EHC cabinet has been designed for automatic control of the injection viscosity of heavy fuel oil in combination with electric heaters. The control action is realized by heating the fuel oil step by step to an appropriate temperature. The built-in viscosity/temperature controller with its programmed setpoint values activates more or less heater relays. The first stage is controlled by means of time proportional control, which enables a linear control of power from zero to a maximum value. The power required at a certain load is adjusted by switching "ON" or "OFF" a number of stages, while the remaining fraction is added by the time proportional control. Consult factory for more details



Electric heater control cabinet

Technical specification

Sensor

Viscosity range	0-25/50 mPa.s (other ranges on request, max. 1000 mPa.s)
Density range*	750-1100 g/l (standard, other ranges on request)
Temperature range	0-200°C
Maximum operating temperature	180°C
Temperature transmitter	PT100 element
Viscosity accuracy	± 2% instantaneous or 0,5 mPa.s
Density accuracy*	± 0,1% instantaneous or 1 g/l
Temperature accuracy	± 1°C
Sensor material	Stainless steel 316L / Ni-alloy*
Coating material	Diamond Like Carbon (DLC)
Protection class	IP65
Cable length	5 m integrated
Weight	1 kg

Interface box

Viscosity, density* and temperature output	Isolated active output 4-20 mA, current loop, max. load 400Ω
Bus*	Modbus over TCP/IP: all measuring data
Power supply	100-230 VAC, 50-60 Hz (fluctuations should not exceed 10% of the nominal voltage)
Power consumption	6 Watt
Response time	Depending on application
Resolution	0,1 mPa.s and 1 g/l
Ambient temperature	-20-55 °C
Humidity range	0-95% RH
Mounting	Wall mounting
Installation category	I acc. IEC 1010-10
Pollution degree	I acc. IEC 664
Weight	2 kg

*ViscoSense*3D only



Interface box

Technical specification

Controller

General	Fully graphic display ¼" VGA TFT with backlight
Control strategy	Single channel or dual channel
Input viscosity & temperature	4-20 mA
Output control contacts	2 relays, 5A/240 VAC (standard) or analogue (optional)
Output current	Galvanically isolated 4-20 mA for retransmission
Alarm feature	Non-latching band alarm
Scale range viscosity	0-25 mPa.s / 0-50 mPa.s (or as ordered)
Scale range temperature	0-200° C
Power supply	100-240 VAC, 48-62 Hz (fluctuations should not exceed $\pm 10\%$ of the nominal voltage)
Power consumption	10 W
Ambient temperature	0-55° C
Operating humidity range	5-95% RH (non-condensing)
Protection class	IP66/NEMA 4X (front only)
Housing for panel mounting	96 x 96 mm
Weight	0,5 kg



Electronic controller

Technical specification

Sensor housing

Material	Ductile iron
Flange connections	Standard DN50 (2"), DIN, ANSI or JIS; other sizes on request
Pressure rating	PN40
Weight	10 kg
<hr/>	
Diameter	<i>max. flow m³/h</i>
DN 50	20
DN 65	34
DN 80	51
DN 100	80



ViscoSense housing



For Viscotherm replacement a retrofit housing is available.
Please refer to Information Bulletin 732

Dimensions

Interface box

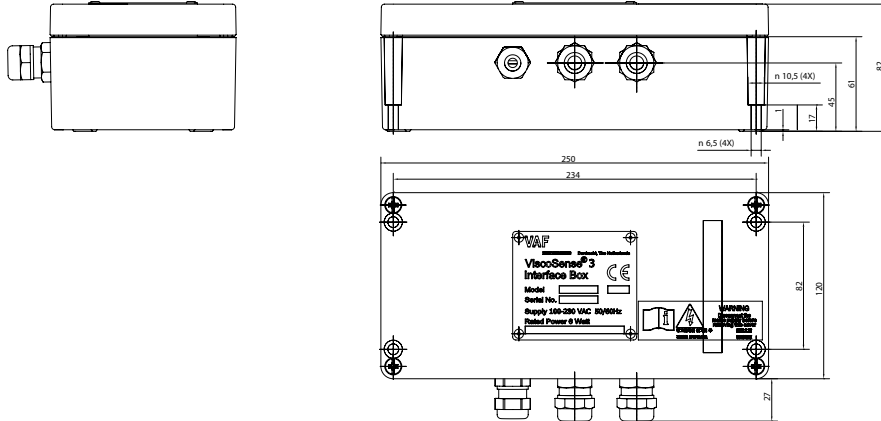

Controller

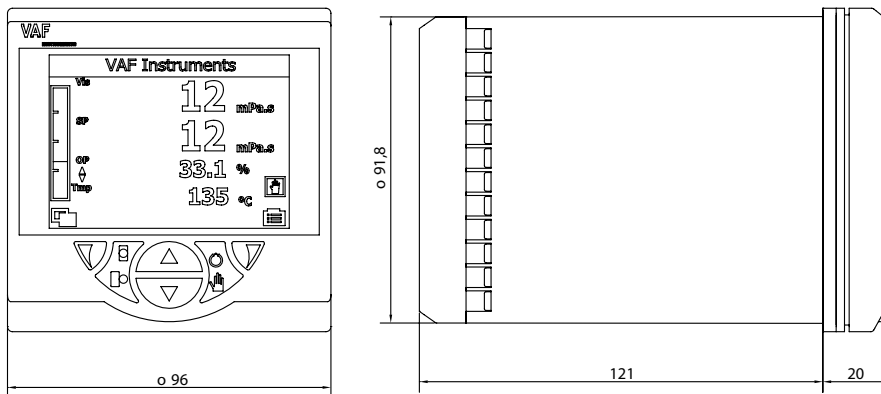

Dimensions

Sensor housing

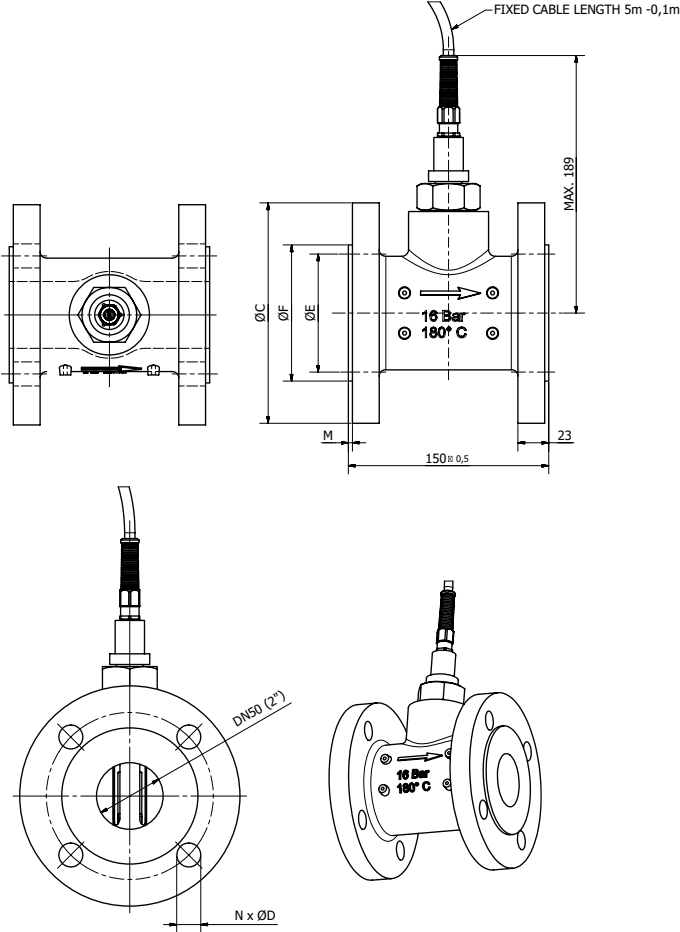

ViscoSense® housing

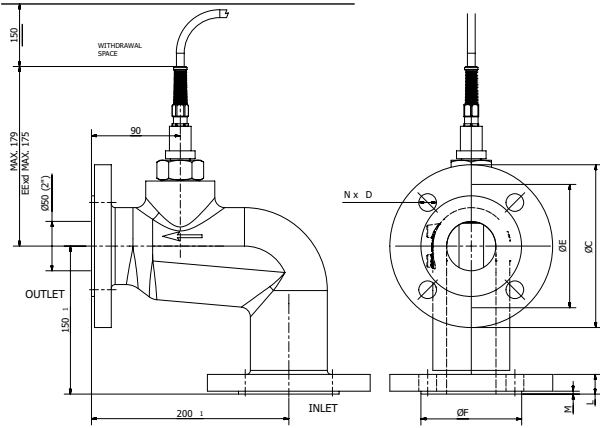

Sensor housing for Viscotherm replacement

Quotation and ordering information

1. Basic system designation:	ViscoSense*3 / ViscoSense*3D		
2. Application:	<input type="radio"/> Fuel viscosity and density measurement	<input type="radio"/> Fuel viscosity control	
	<input type="radio"/> Viscotherm retrofit	<input type="radio"/> ViscoSense® retrofit	
	<input type="radio"/> Mass flow measurement (please consult factory)	<input type="radio"/> Bunker receipt / supply (please consult factory)	
3. Viscosity range:	<input type="radio"/> 0 - 25	<input type="radio"/> 0 - 50	<input type="radio"/> special:
4. Viscosity reading [unit]:	<input type="radio"/> mPa.s	<input type="radio"/> cSt	
5. Density range [g/l]:	<input type="radio"/> 750-1100 (standard)	<input type="radio"/> Other:.....	
6. Temperature range [°C]:	<input type="radio"/> 0 - 100	<input type="radio"/> 0 - 200	
7. Fluid type:	<input type="radio"/> HFO	<input type="radio"/> MDO	
	<input type="radio"/> MGO	<input type="radio"/> Other:.....	
8. Flow rate [m3/h]:			
9. Nominal diameter of piping:			
10. Flange type:	<input type="radio"/> DIN PN [bar]	<input type="radio"/> ANSI [lbs]	<input type="radio"/> JIS [K]
11. Optional extras:	<input type="radio"/> viscosity controller <input type="radio"/> remote indicator <input type="radio"/> control valve <input type="radio"/> flow computer / read-out for mass flow (please consult factory) <input type="radio"/> inspection by classification bureau, bureau name:		

Below information is only required when 'control valve' is selected in question 11.

12. Control valve:			
actuation	<input type="radio"/> electric (relay)	<input type="radio"/> electric (analog)	
medium	<input type="radio"/> steam	<input type="radio"/> thermal oil	
body material	<input type="radio"/> ductile iron	<input type="radio"/> steel	
flange connections	<input type="radio"/> DIN PN [bar]	<input type="radio"/> ANSI RF [lbs]	<input type="radio"/> JIS [K]
13. Nominal diameter of piping:			
14. Inlet pressure [bar]:			
15. Nominal flow rate [for steam in kg/h, liquids in m3/h]:			
16. Allowable pressure drop across valve [max. 1 bar]:			
17. Specific gravity of medium [water=1,0]:			

Please fill out this form and send it to sales@vaf.nl. We will reply with a quotation and ordering information for the requested product or solution a.s.a.p.

For further information see relevant Product Bulletins or www.vaf.nl

Name:

Place and date:



All copyrights reserved | Publ. No. PB-782-05-0319 Supersedes PB-753-05-0217 and PB-774-05-0217

VAF

INSTRUMENTS

VAF Instruments B.V.
Vierlinghstraat 24, 3316 EL Dordrecht, The Netherlands
P.O. Box 40, 3300 AA Dordrecht, The Netherlands
T +31 78 618 3100 | info@vaf.nl | www.vaf.nl

Specifications subject to change without notice
VAF Instruments B.V. is an ISO 9001 Certified Company
Agents and distributors in more than 50 countries

